



Body Workforce Camera User Guide



Models: AX1023, AX1024, AX1025

Rev: 07 Apr 2025

Axon Enterprise, Inc.
17800 N 85th St
Scottsdale AZ 85255
USA

▲, ▲ AXON, Axon Body, Axon Body Workforce, Axon Dock, and Axon Evidence are trademarks of Axon Enterprise, Inc., some of which are registered in the US and other countries. For more information, visit www.axon.com/legal. All other trademarks are property of their respective owners.

All rights reserved. ©2025 Axon Enterprise, Inc..

Contents

Introduction and registration	1
Important safety and health information	1
Additional reading	1
Register camera	1
Registration with Axon Device Manager	2
Get to know your camera	4
Button actions	4
Accessories and mounts	6
Configure your camera	8
Adjust volume	8
Light setting	8
Camera vibration	8
Axon Signal	9
Other settings (admin)	9
Operate your camera	10
Operating modes	10
Turn on the camera and Ready mode (buffering)	10
Start Recording mode (event)	11
Mute audio recording	11
Stealth mode	11
Add markers while recording	12
Illuminate the camera display	12
Battery status	12
Sleep mode	12
Device pooling	13
Multi-factor authentication (MFA)	14
Watch Me	16
Priority upload	17
Start a Priority upload	17
Cancel an upload	18
Error states and edge cases	19
Automatic Wi-Fi upload	21
Advantages	21
In Axon Evidence	21
Set up a network	21
Enable Automatic Wi-Fi Upload	23
On the camera	23

What triggers Wi-Fi	23
Receive a firmware update over Wi-Fi	24
Disable Wi-Fi Upload on camera	25
Check camera storage	26
Wi-Fi and priority	26
Frequently Asked Questions	26
Icons, LEDs, and sounds	28
Visual notifications	28
Icons and Triad LEDs while docked	29
Audible and haptic notifications	30
Admin settings	31
Video	31
Pre-Event Buffer and Video Recall	31
Watermark	31
Audio	31
Lights	32
Location	32
Axon Respond	32
Evidence upload	33
Axon Signal	33
Gunshot detection (beta)	33
Remote activation	34
Battery	34
Firmware download	34
User permissions and mute configuration	34
Device management	35
Button confirmation	35
Care and maintenance	36
Clean and disinfect the camera	36
Surface	36
Lens	36
Approved cleaning agents	36
Charge the battery	37
Charge without a dock	37
Internal clock	38
Update firmware	38
Moisture	38
Camera storage	38
Troubleshooting	39
General FAQs	39
Axon Dock FAQs	41

Camera registration FAQs 42

ADM error codes 43

View camera information on the display 45

Technical information 46

 Technical support 46

 Warranty 46

 Warnings 46

 Radio waves 46

 FCC compliance statement 47

 ISED Canada compliance statement 48

 Declaration of conformity and EU compliance statement 49

 Compliance marks 49

Introduction and registration

Axon Body Workforce (ABW) is a body-worn camera system for use in retail and enterprise environments. The camera records events for secure storage, retrieval, and analysis on Axon Evidence.

Body Workforce does not support offline mode and is not compatible with Evidence Sync.

Watch this [video](#) for an introduction to your body camera.

Important safety and health information

Read, understand, and follow all warnings and instructions before using this product. The most up-to-date warnings and instructions are available at www.axon.com.

Additional reading

This manual discusses how to operate the camera. Other manuals cover additional aspects of the camera system. These documents are available at help.axon.com.

For details on working with uploaded videos and managing cameras, including inventory management and organization-wide settings, see the [Axon Evidence User and Administrator Reference Guide](#).

For details on installing and setting up the dock to transfer information and recharge your camera, see the **Axon Dock** section (or PDF) on your camera's [product page](#) at my.Axon.

Links to [Axon Academy](#) training videos appear in relevant topics of this guide, including how to register for and use the Axon Evidence website, configure settings, assign personnel to cameras, recharge your camera, and transfer video to a computer.

Register camera

Cameras must be registered by your organization before they can be assigned to users. Additionally, you should adjust the organization-wide camera settings in Axon Evidence before assigning cameras to users.

Registering with Axon Device Manager (ADM) requires:

- ADM installed on an appropriate device. If you already have ADM installed, ensure you have the latest version of Android or iOS installed.

Note

You must have device management permissions to use ADM. If you aren't sure if you have permissions to use ADM, contact an Axon Evidence administrator.

- A Body Workforce Dock connected to power and the internet (green ■ LED visible on the WAN port).

Registration with Axon Device Manager

This section describes how to register your camera using [Axon Device Manager](#) (ADM) and the camera dock. Adjust the organization-wide camera settings in Axon Evidence in the Admin section prior to assigning. This requires [device management permissions](#).

You can register up to 100 cameras at once if you have an Axon Dock for each camera. You must keep your mobile device with ADM within 30 feet of all the cameras.

1. Press **Power** until you feel a short vibration.
2. Place the camera in a networked dock.
3. Log into ADM and tap **Settings** .

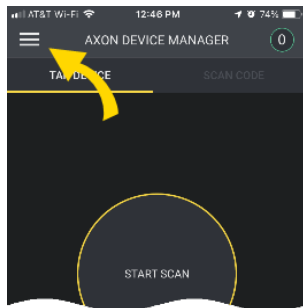

4. Go to Registration, select **Devices**, then your camera.

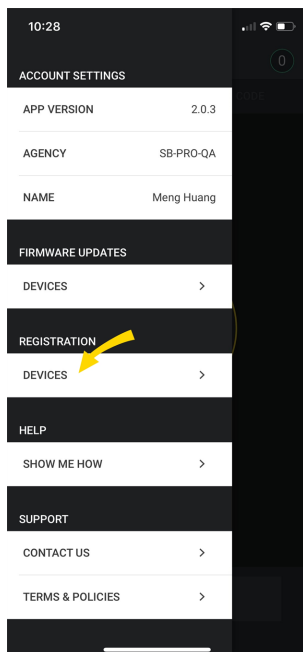

5. Review the device registration setup and tap **Next** **NEXT** to move to the next screen.

Tap **Start Scan** **START SCAN** to start the registration process.

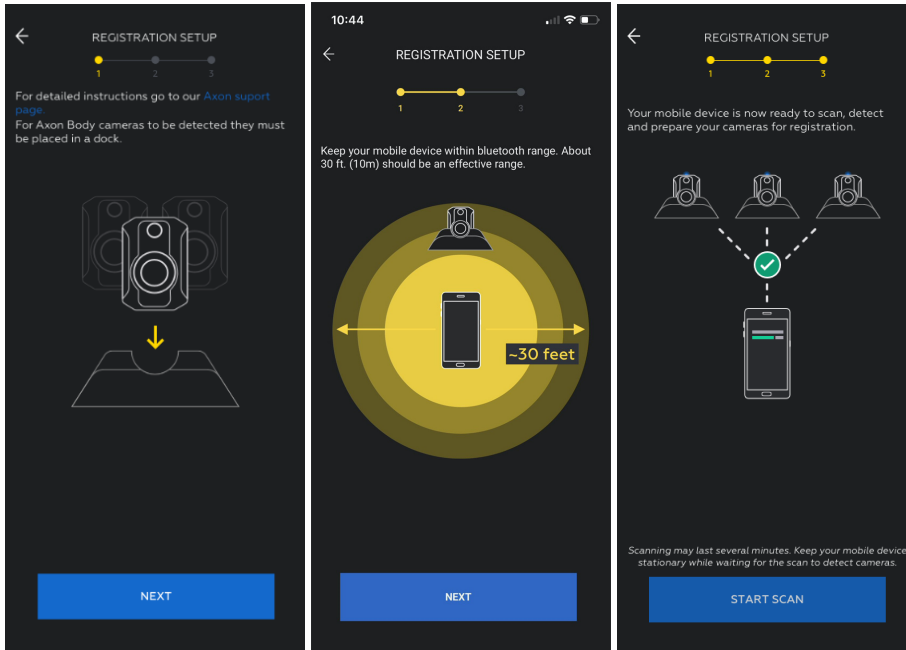

6. ADM detects and prepares unregistered cameras. The number of detected and prepared cameras appears at the top of the ADM screen.

- Press **Select** (between the volume buttons) on each camera to proceed with the registration.
- If successful, the display shows **NOT ASSIGNED** to indicate the camera is ready to be assigned to a user.

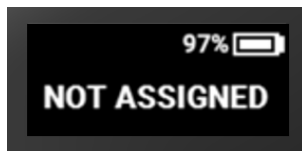

7. When you have registered all the detected cameras, select **Finish**. ADM shows a list of camera serial numbers that have been registered during this session.

Successfully registered cameras can be charged and assigned to users.

Get to know your camera

Button actions

There are several buttons and features that perform as described below.

Front view

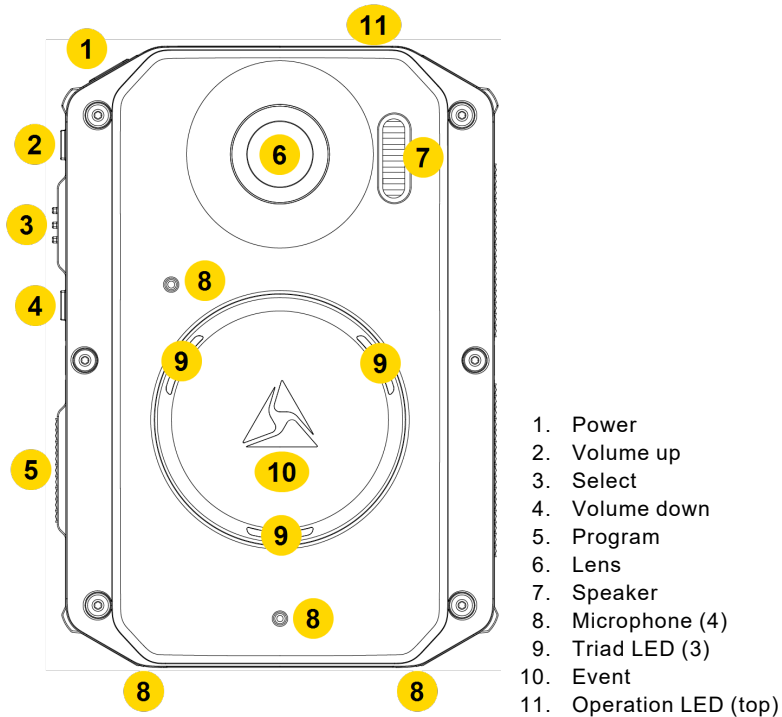

- 1. Power
- 2. Volume up
- 3. Select
- 4. Volume down
- 5. Program
- 6. Lens
- 7. Speaker
- 8. Microphone (4)
- 9. Triad LED (3)
- 10. Event
- 11. Operation LED (top)

Action	Button Presses
Lights	Press Volume Up ▲ for three second, then tap to toggle modes
Marker, add	Press Select while recording
Menus	Press Program and Power simultaneously
Mute on/off	Press Select for three seconds while recording
Pairing	Press Event + Program simultaneously
Power off	Press Power for three seconds
Power on	Press Power until short vibration
Recording start	Double-press Event
Recording stop	Press Event for three seconds
Sleep mode, enter	Press Power then Select to confirm

Action	Button Presses
Sleep mode, exit	Press Power or start a recording
Stealth mode, enter	Press Volume Down for three seconds*
Stealth mode, exit	Press Volume Up ▲ or Volume Down ▼ for three seconds*
Volume, speaker	Press Volume Up ▲ or Volume Down ▼

* The camera remembers the previous volume and light settings when exiting Stealth mode.

For details on screen icons and meanings of both the top Operation and front Triad LEDs, see [Icons, LEDs, and sounds](#) on page 28.

Top view

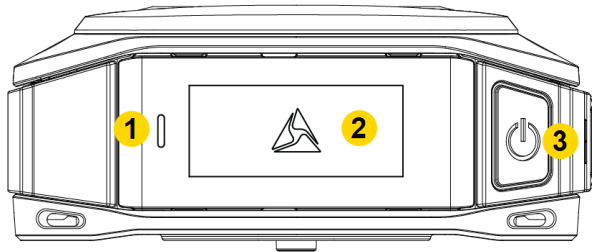

- 1. Operation LED
- 2. Display
- 3. Power

Camera Display – Shows information on camera status and activity. Different information appears depending on if the camera is in the field and in an Axon Dock. Some icons may not be active at your organization. The display is divided into a Status Bar and Activity Area.

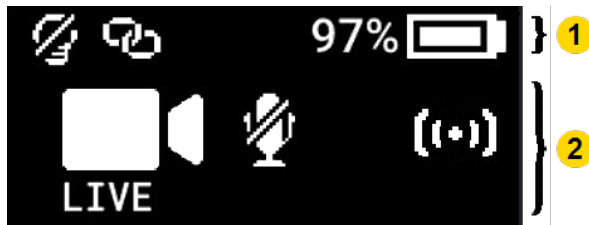

- 1. Status Bar
- 2. Activity Area

For details on all the icons that may display both in the field and during dock charging, see [Icons, LEDs, and sounds](#) on page 28.

Bottom view

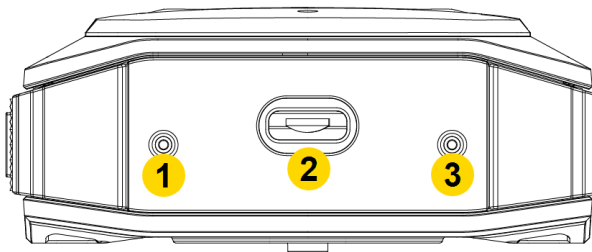

- 1. Microphone
- 2. USB-C connector
- 3. Microphone (model AX1023)

- **USB-C connector** – Used for data transfer and charging when placed in an Axon Dock.
- **Microphone** – Used to record audio.

Accessories and mounts

The Workforce camera works with a variety of Axon mounting systems.

Note

As with any radio frequency or electronic device, Axon recommends to avoid placing the camera directly next to your radio to prevent inadvertent radio activation.

The various mounts that use this system can be used with a wide variety of uniforms to fasten the camera to your shirt, vest, or jacket. The magnetic lanyard mount can be worn like a necklace or fastened with a layer of light-duty clothing (such as T-shirt, polo, apron, or scrubs) in between as shown here:

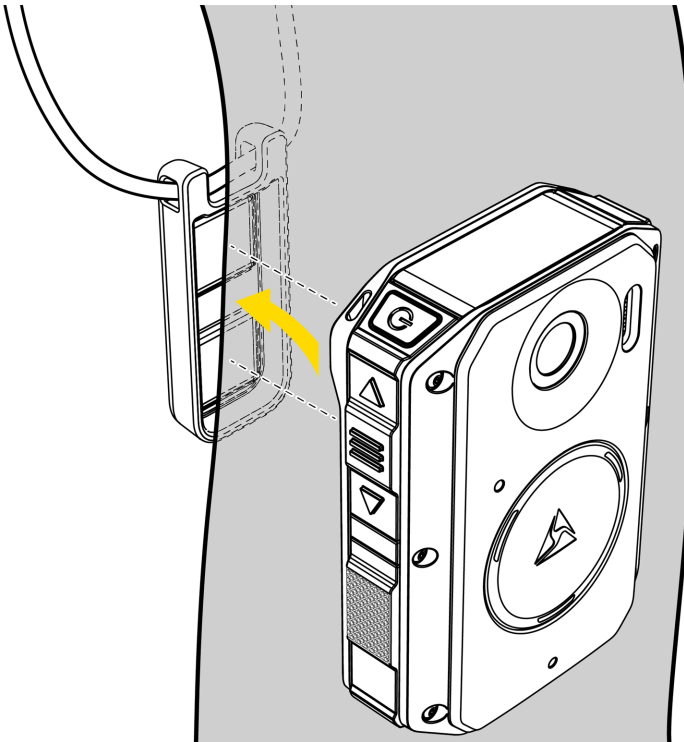

If your clothing is too thick for the magnets to connect securely, wear the lanyard over your clothing.

In general, Axon mounting systems consist of the attachment piece (called the key) on the camera and the attachment receiver (called the lock) on the mount. To lock a camera in place, insert the key of the camera into the lock of the mount (the camera will typically be sideways) and turn it 90 degrees counterclockwise (when you are looking straight at the mount). To release the camera from the mount, turn the camera 90 degrees clockwise.

Watch this [video](#) for an overview of using the magnetic lanyard.

Watch this [video](#) for an overview of switching lanyards and charging in the dock.

You can find further information on mounting options, including demonstration videos, on my.Axon at [Body-Worn Camera Mounting Options](#).

Configure your camera

During normal operation, the camera uses lights, sounds, and vibrations (haptic feedback) to notify you of the camera status. These indicators and notifications are managed by your organization and can be configured to allow you to change the setting for your assigned camera.

Check with your Axon administrator to learn which configuration settings you can change.

Adjust volume

During normal operation, the camera emits beeping sounds, called audio prompts, to notify you of the camera status.

To adjust camera audio prompt volume:

Use camera controls

Use **Volume Up ▲** and **Volume Down ▼** to adjust the volume. The camera provides audio feedback and indicates the volume setting on the camera display as the volume changes.

Light setting

During normal operation, the camera shows camera status using LEDs. For a description of what the different colors indicate, see [Icons, LEDs, and sounds](#) on page 28. Settings or the ability to change them may be restricted by your administrator.

The camera has the following light settings:

- Lights off
- Lights dim
- Lights auto (automatically adjusts lights based on ambient lighting)

To change the brightness of the LEDs:

Use camera controls

To change the brightness of the LEDs, press **Volume Up ▲** for three seconds to turn lights off; the **Lights out** icon  appears on the display. To turn lights back on, press **Volume Up ▲** for three seconds, then press again for other lighting options.

Camera vibration

During normal operation, the camera uses vibrations (haptic feedback) to indicate camera status. Haptic feedback can't be modified.

Axon Signal

This camera is compatible with Axon Signal technology. Your administrator must activate Axon Signal capability prior to use.

When it is active, Axon Signal technology can broadcast a signal that allows your camera to transition from Ready to Recording mode automatically. When your camera starts recording, you will see, hear, and feel all the normal start-recording notifications.

Axon Signal technology transmissions only allow cameras to start recording. Axon Signal technology does not transmit a signal to end recording. The camera must be stopped manually.

Axon Signal technology cannot power an Axon camera on. If the camera is off, it will not record.

Devices equipped with Axon Signal technology have a signal range of approximately 30 feet (9.1 meters) and can be purchased separately from the Axon Body camera.

Other settings (admin)

Your organization's Axon administrator can configure additional settings and functionality (such as video quality and pre-event buffer time) for your camera. The list of options is in [Admin settings](#) on page 31. Check with your Axon administrator for information about which settings and functionality are available for your camera.

Operate your camera

Before operating an Axon Body Camera, ensure it is fully charged and properly configured. For details, see [Charge the battery](#) on page 37.

Operating modes

This camera has two operating modes:

- Ready (Buffering) – Camera is on and is pre-event buffering
- Recording (Event) – Camera is recording

Turn on the camera and Ready mode (buffering)

Press **Power** until you feel a short vibration. The camera emits two short rising-pitch tones with a long vibration and then enters Ready (Buffering) mode.

When the camera is in Ready mode:

- The camera display shows READY
- The Operation LED on top of the camera blinks green 
- The camera is capturing video but not recording to permanent memory

The pre-event buffer is configurable between 0 and 120 seconds, but set at 30 seconds by default.

When Recording (Event) mode is activated, the buffered video captured directly before the event is saved and attached to the event in permanent memory. This feature captures the video of an incident just before a recording begins. The camera does not capture audio within the pre-event buffer by default (but can be set to do so by an admin).

Ready mode starts when the camera is turned on. It does not buffer video when the camera is turned off, in [Sleep mode](#) (see page 12), or docked.

Start Recording mode (event)

1. To begin recording, double-press **Event**. When your camera starts recording, it emits two short tones and two short vibrations and the display shows the recording icon. The camera provides indications it is in Recording mode:
 - The camera display shows STARTING and then the recording icon.
 - The Operation LED on the camera blinks red ■■■■.
 - The camera emits two short tones and two short vibrations every two minutes as a recording reminder.
2. To stop recording and return to Ready mode, press **Event** for three seconds. The camera emits one long tone and vibrates. The camera display shows SAVING and then READY and the Operation LED blinks green ■■■■.

Watch this [video](#) for an overview of this function.

Watch this [video](#) for an overview of livestreaming while recording.

Mute audio recording

If your organization's administrator has configured your camera to do so, you can mute audio while recording video. The two-minute recording reminder tone will differ from normal to alert you when a recording is muted.

1. Press **Select** for three seconds to mute audio capture. The microphone off icon appears on the camera display and the Operation LED blinks blue ■■■■ while the camera is muted.
2. Press **Select** another three seconds to cancel mute.

Stealth mode

Use Stealth mode to turn off the LEDs, sounds (audio prompts), and vibrations (haptic feedback) on your camera. This is useful for both tactical situations and when dealing with members of the public with light/sound sensitivity.

To enter and exit Stealth mode:

Use camera controls

- To enter Stealth mode – Press **Volume Down ▼** for three seconds. The word STEALTH shows briefly on the camera display activity area and an **S** icon appears in the display.
- To exit Stealth mode – Press **Volume Up ▲** or **Volume Down ▼** for three seconds. The **S** icon disappears from the display.

Watch this [video](#) for an overview of this function.

Add markers while recording

Markers are useful for indicating an important event that you want to easily find when replaying the video. The marker is shown when the video is replayed in Axon Evidence and documented in the audit trail.

To add a marker to a video while you are recording, press **Select**. The camera vibrates once.

Watch this [video](#) for an overview of this function.

Illuminate the camera display

In low-light situations, double-press **Select** to illuminate the camera display for five seconds.

To change light settings, see [Change light settings](#) and [Stealth mode](#) starting on page 11.

Battery status

The battery capacity for your camera appears on the camera display as a percentage. The Operation and Triad LEDs also reflect battery level; see [Icons, LEDs, and sounds](#) on page 28.

Sleep mode

Sleep mode puts the camera in an idle state that disables recording and buffering. While in this state, an automatic activation enabled at your organization will not initiate camera recording.

Note The ability to use Sleep mode is enabled by your organization Axon Evidence administrator and may not be available at your organization.

Sleep mode is useful for situations where camera users may need momentary privacy. You can enter Sleep mode from the buffering state in less than three seconds, as opposed to turning the camera completely off. Similarly, the camera will exit Sleep mode and enter a buffering or recording state in less than three seconds.

The device audit trail reflects when Sleep mode is entered and exited. While Sleep mode can be used as an alternative to completely powering down the camera during private situations, it should not be considered a replacement for powering the camera off. Certain background processes are running while the camera is in Sleep mode and the battery still depletes while in this mode, but at a slower rate.

Enter and exit sleep mode

To enter Sleep mode:

1. Press **Power**.
2. With **Sleep** selected, press **Select** to enter sleep mode.

To exit Sleep mode, either:

- Press **Power** to return the camera to buffering state, or
- Press **Event** twice to begin recording.

Watch this [video](#) for an overview of this function.

Device pooling

Cameras shared between users are considered part of a pool. A pooled camera in an Axon Dock is not available for use until evidence is offloaded and its battery reaches 70% of full charge (if your camera requires 90%, leave it in a networked dock for at least eight hours so it can receive a firmware update). Once assigned via the device pooling kiosk, the camera's LED flash rate increases and the screen color inverts to make it easier to find among other cameras still charging. For details on device pooling, contact your Axon representative.

The RFID bulk import capability for device pooling simplifies the management of RFID card assignments by letting you efficiently create multiple simultaneous RFID card-to-user mappings using CSV file imports. The interface centralizes the viewing, searching, and removal of RFID assignments and supports bulk creation, deletion, and management of RFID card-to-user mappings, with options to download backup, template, and error files for streamlined system management and error handling.

Watch these videos for an overview of how to:

- [Check out a device](#)
- [Enable self-checkout for devices](#)
- [Configure the device pooling kiosk](#)

Multi-factor authentication (MFA)

Note

For MFA to be available on a body camera, your Axon administrator must:

- Enable camera as an MFA method for your agency.
- Ensure cameras are on the latest firmware.
- Ensure the camera is assigned to the user.
- Ensure the camera is not in a lost or stolen state.

Your body camera can function as an MFA device (sometimes called Two-Factor Authentication, or 2FA).

1. Sign into Axon Evidence (or other apps).
2. Select **Body camera** from the MFA select screen.

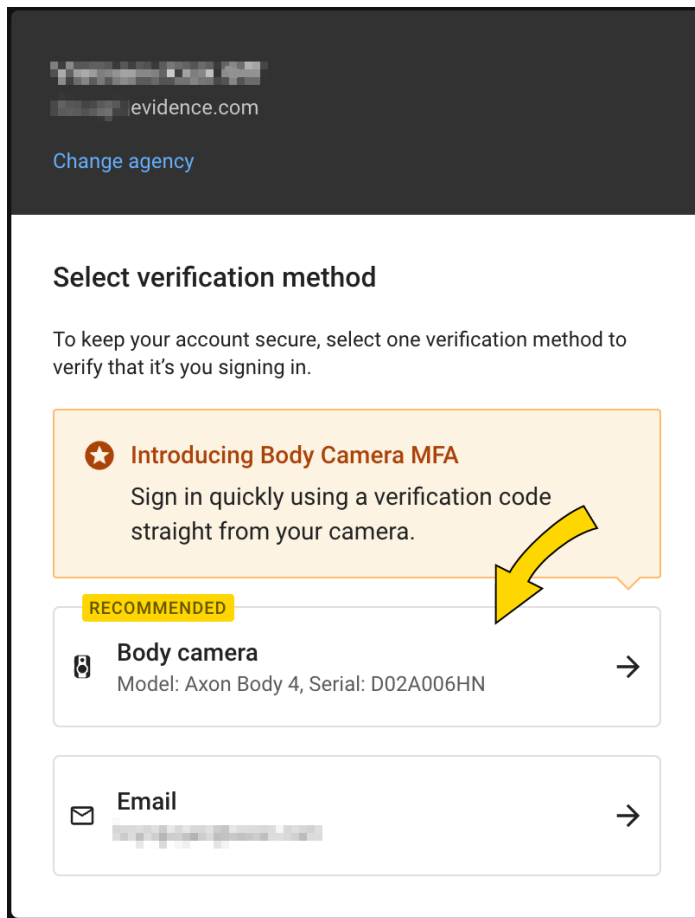

3. On your body camera, long-press **Program** (below **Volume down ▼**) to use the MFA shortcut. Or...

4. Press **Power** and **Program** (below **Volume down ▼**) simultaneously to open the menu, press **Volume down ▼** to reach **Authenticator**, then press **Select**.



5. Use the MFA code displayed to sign in. The progress bar at the bottom shows when the code will refresh.

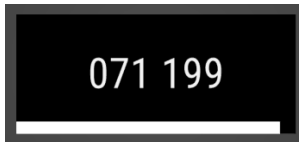

MFA may start midway through a code cycle, depending on when you request it. The camera returns to the main screen after 60 seconds or with any button press.

You can use the shortcut to access the MFA screen while recording unless your agency has assigned it to a different action.

Learn more at [MFA User Guide](#) and (for admins) [MFA Admin Guide](#).

Watch this [video](#) for an overview of this function.

Watch Me

Watch Me gives anyone wearing a Body Workforce camera a simple way to request supervisors, command staff, and dispatchers to quickly view their livestream.

Watch this [video](#) for an overview of the Watch Me function.

To request a second pair of eyes, double-press the program button to alert Respond users. Supervisors and command staff can tap on the notification or the purple bubble to quickly view the user's livestream and provide real-time assistance.



1. Program button

If the camera is buffering, a Watch Me request will start a recording. If the camera is already recording, it will continue recording after the Watch Me request. To cancel a Watch Me request, simply long-press **Event** to end the recording.

[Granular permissions](#) let admins configure Watch Me notifications to work in conjunction with your organization's organizational structure using [Command hierarchy](#). With command hierarchy enabled, select **Only in their command** in the **View BWC locations** user role settings. Given this user role configuration, users assigned this role will only receive notifications from camera wearers under their command in the command hierarchy.

Watch Me requests are only sent to users permitted to view the livestream (they have access to the livestream associated with the request).

Priority upload

Priority upload lets you wirelessly upload the most recent recording on your body camera to Axon Evidence using its LTE connectivity.

Several factors can affect the performance, speed, and battery impact of uploading over LTE. With strong LTE coverage, a 15-minute recording at 720p High will take five minutes to upload and use about 2%, or 12 minutes, of battery capacity. With poor LTE coverage, this same recording may use about 4%, or 24 minutes, of battery capacity.

The camera can continue to buffer or record normally while uploading over LTE.

This feature is only available for Axon Respond for Devices+ organizations. Axon Evidence administrators can enable it by turning on the Priority Evidence Upload setting on the camera settings page:

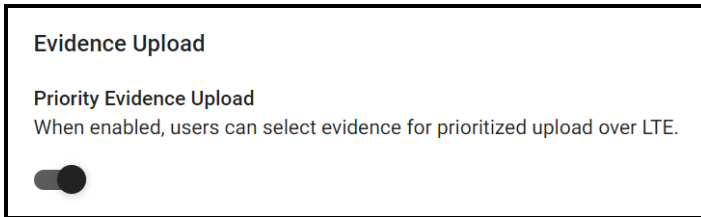

Watch this [video](#) for an overview of this feature.

Start a Priority upload

1. Press **Program** and **Power** simultaneously to open the diagnostic menu.

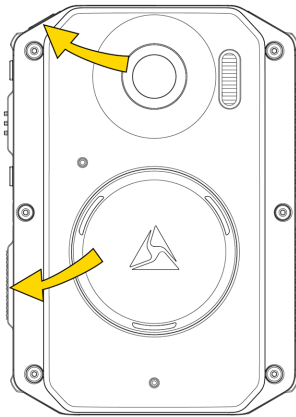

2. Press **Select** (between the volume buttons) to select **Upload**.

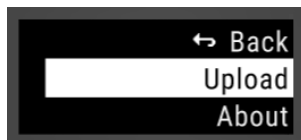

3. Select **Priority Upload**. If there is no recording on the device, the display shows **NO EVIDENCE**.

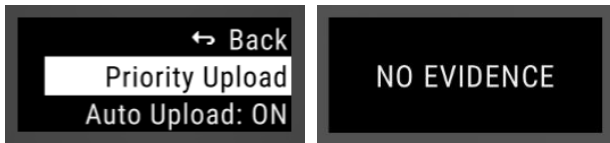

4. If there is a recording on the device, the top of the screen shows its start time followed by the duration in parenthesis. Use the volume buttons to select either **BACK** (upload nothing) or **START** (uploads the last saved recording), then press **Select**.



Once an upload has started, the display returns to its normal view of showing if the camera is **Ready** or **Recording**, along with the upload icon  at the bottom right.



The diagnostic menu option changes from **Upload** to **Uploading** when an upload is in progress.



Once the recording has uploaded, the camera vibrates and then deletes it from the camera.

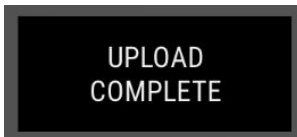

Cancel an upload

1. Open the diagnostic menu.
2. Select **Uploading**.



3. Select **CANCEL**.

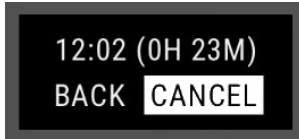

A message confirms the cancellation and the recording remains on the device.

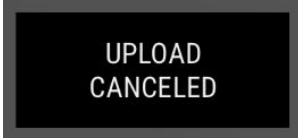

Error states and edge cases

Upload over LTE may encounter the following errors.

Evidence exceeds upload limit

Recordings longer than 60 minutes cannot be completed using LTE due to the size of the file. Dock the camera or use View XL standalone mode.

Upload paused: poor signal

The camera pauses uploaded if it loses LTE coverage during an upload, displaying  at the bottom right. If LTE coverage returns within 10 minutes, the upload will resume, otherwise it cancels and the recording remains on the camera.

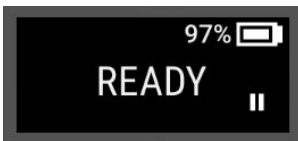

Upload paused: USB-C connected

An LTE upload pauses when you connect a USB-C cable. The upload will resume when you disconnect the cable.

Camera shut-down due to low battery

If the camera shuts down due to a low battery during an LTE upload, the upload pauses and the recording remains on the camera. The upload will resume when the camera is turned back on with sufficient charge.

Docked camera

If you dock your camera during an LTE upload, the upload will continue using the dock's ethernet connection, with the Priority upload taking priority.

Upload timed out

If the upload takes longer than two hours (which may occur if LTE coverage is poor and/or the file size is large), the upload pauses. Select to **RESUME** or **CANCEL** the upload.

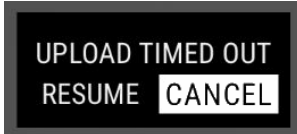

Upload paused: livestream

An LTE upload pauses  to allow a requested livestream. The upload resumes when the livestream ends.

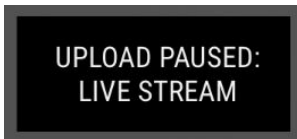

Automatic Wi-Fi upload

This feature lets cameras upload videos and update (download) firmware over Wi-Fi when an approved network is available. It is available for all camera users and requires no separate licensing.

This article describes how to set up a body camera Wi-Fi network, what happens on the camera during a firmware update over Wi-Fi, how to confirm an upload, what takes priority over Wi-Fi, and frequently asked questions (FAQs).

Your Axon Evidence administrator can enable this feature in the Admin section. Admins should also reference:

- [Enterprise Wi-Fi Network Quick Start Guide](#)
- [Personal Network Management](#)

Advantages

When connected to an approved Wi-Fi network, a body camera will:

- Sync the clock once per day
- Sync changes made in the Axon Evidence camera settings page, including the list of approved Wi-Fi networks
- Upload recordings
- Download and install firmware updates

When connected to a dock, communication occurs over the wired connection (if available), even if Automatic Wi-Fi Upload is enabled. Wi-Fi communication halts whenever the camera is docked, whether it is networked or not, but will continue if charging through a USB-C cable.

Registration is the only non-supported Wi-Fi operation (use ViewXL Standalone or a networked dock).

In Axon Evidence

Set up a network

This section describes how to create an approved Wi-Fi access point that body cameras can use to upload recordings and download updates.

1. In Axon Evidence, select **Admin > Body Camera Wi-Fi Networks**.
2. Select **Add Network**.

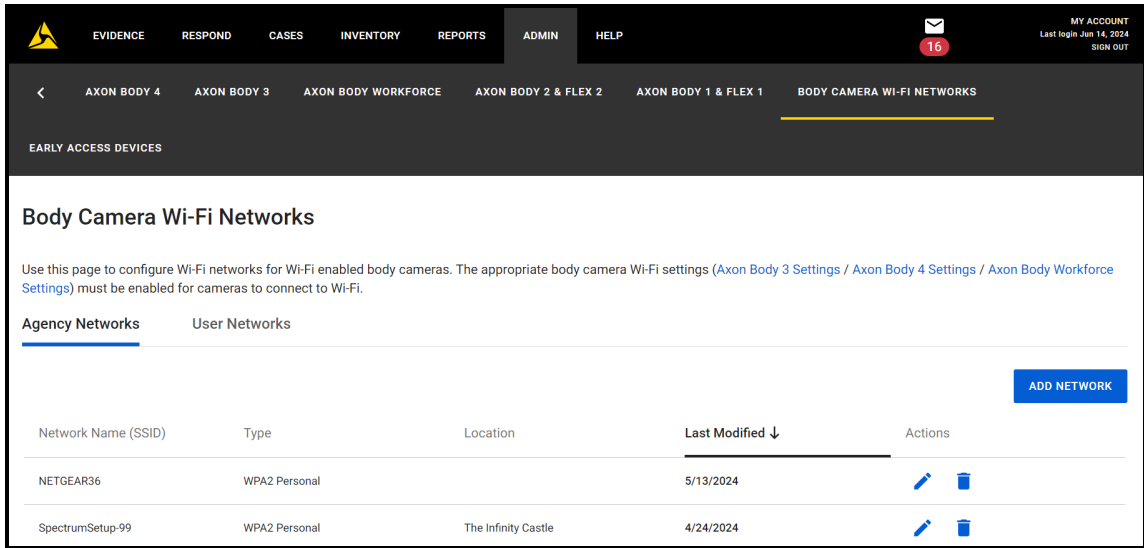

3. Enter the **Network Name (SSID)** and **Password**. Optionally, add **Location** information to differentiate networks with similar names.

The 'Add Network' modal form contains the following fields and elements:

- NETWORK TYPE ***: A dropdown menu with 'WPA2 Personal' selected.
- Credentials** section:
 - NETWORK NAME (SSID) ***: A text input field containing 'SSID'.
 - PASSWORD ***: A password input field with a visibility toggle icon.
- Notes** section:
 - LOCATION**: A text input field containing 'Location'.
 - A character count '0/100' is displayed below the location field.
- At the bottom, there are 'CANCEL' and 'SAVE' buttons.

A note at the bottom of the form reads: "Axon recommends using only WPA2-PSK (AES) networks. See MyAxon for additional Wi-Fi information."

Note While WPA2-TKIP, WPA, and WEP are supported, Axon recommends using WPA2-PSK networks for increased security.

4. Select **Save**.
5. Add more networks as needed.

6. Use **Edit**  and **Delete**  to manage existing networks.

Enable Automatic Wi-Fi Upload

1. Select **Admin > Axon Body Workforce (ABW)**.
2. If applicable, select the appropriate profile.
3. Under **Evidence Upload**, toggle **Automatic Wi-Fi Upload** on.

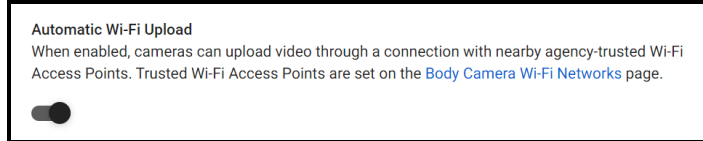

4. Scroll to the bottom and select **Save Profile Settings**.

Axon Body Cameras download updates to the network list the next time they are docked or can access an approved Wi-Fi network.

On the camera

What triggers Wi-Fi

These situations will cause the camera to communicate over Wi-Fi:



1. At the end of a recording. If multiple networks are available, it will use the one with the strongest signal strength. The camera checks for an approved network every 15 minutes.
2. If the feature is [disabled](#) (see page 25) and then re-enabled on the body camera.
3. When the camera is charging through a USB-C cable.

Wi-Fi communication will pause if the camera:

- Loses connection to approved Wi-Fi
- Stops charging via USB-C
- Drops below 20% battery
- Begins recording

Receive a firmware update over Wi-Fi

To receive a firmware update, the camera goes through the following steps.

1. The camera downloads the new firmware.
2. The camera displays **Wi-Fi**  when it is connected and **Download**  when downloading.



3. Once the firmware has downloaded, press **Select** (between the volume keys) at the opt-in prompt to install.

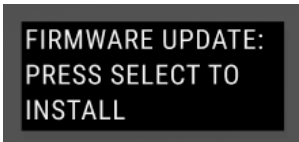

Note

Because this will restart the camera, don't install if the camera is in active use.

4. During installation, the LEDs flash white and the screen displays **Installing** .

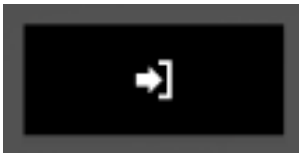

5. After installation, the camera restarts with the latest firmware.
6. If you ignore the opt-in prompt, it will disappear after 60 seconds and the camera will return to the Ready state.

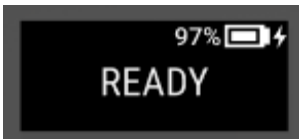

7. If the prerequisites for updating over Wi-Fi are still not met after four hours because the camera is in use, press **Select** to opt-out of (cancel) the installation.

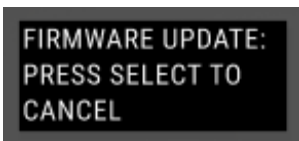

8. If you don't cancel within 60 seconds of this message displaying, the firmware will install and the camera will restart as noted in step 4.

Disable Wi-Fi Upload on camera

If your network is overloaded or you have large recordings to upload, you may not want to upload wirelessly even though your admin has enabled it. You can disable wireless upload on your body camera:

1. Press **Program** and **Power** simultaneously to open the diagnostic menu and use **Select** (between the volume keys) to choose **Upload**.



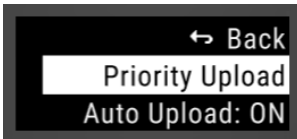

2. If your organization has **Respond+** or the **Priority Evidence Upload** add-on, the first option listed will be **Priority Upload**. If not, it will be **Auto Upload** and whether it is ON or OFF.

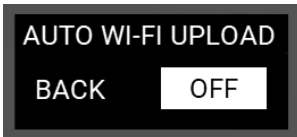

3. To disable the Wi-Fi upload feature, select **Auto Upload** and then **OFF** using the volume buttons. To turn the feature back on later, return here and select **ON**. To cancel, select **BACK**.



4. Once a camera connects to approved Wi-Fi and begins uploading, the screen displays **Wi-Fi**  and **Upload** .

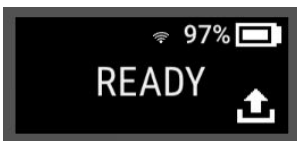

5. When the upload completes, the camera vibrates and then deletes the recording from the camera.

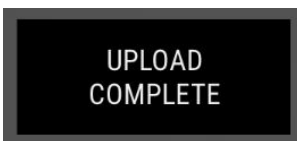

Check camera storage

Automatic Wi-Fi Upload makes wireless uploading, well, automatic. As long as you're within range of an approved Wi-Fi network, recordings upload and updates download. To confirm an upload, check the camera's storage menu.

1. Press **Program** and **Power** simultaneously to open the diagnostic menu.
2. Press **Volume Down ▼** to find **About** and select.
3. Move down and select **Storage**.

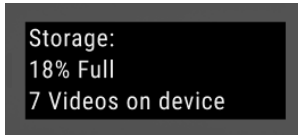

Wi-Fi and priority

In general, Wi-Fi communication will occur if the feature is on and an approved network is available, but other app or camera connectivity functions take priority.

- If a Wi-Fi network connection is lost or interrupted during upload, the upload pauses and resumes when reconnected.
- Wi-Fi connectivity to Axon applications such as Axon View or Fleet 3 Dashboard take priority over Wi-Fi communication.
- If you use Respond or Respond+, LTE connectivity for Respond-related activities take precedence over Wi-Fi communication. For example, if you start recording during a Wi-Fi upload, the upload will pause for livestreaming connectivity.
- Wi-Fi upload will not occur while recording to Wi-Fi or if already processing a Priority upload.

Frequently Asked Questions

If your question isn't answered here, contact [Axon support](#) or your Axon representative for more information.

How long must a camera be docked to receive an updated list of Wi-Fi networks?

Dock your camera or connect to View XL for at least two minutes to receive changes to settings, including Wi-Fi networks. An icon on the screen shows if it is downloading .

Do recordings wait to upload until they are tagged?

No. Recordings upload when connected to a networked dock or approved Wi-Fi network. After upload, they are deleted from the device and no longer visible or editable using Axon View, View XL, or Fleet Dashboard. You can edit recording metadata in Axon Evidence.

How does this feature affect battery charge?

The effect on battery is proportional to how often a camera is recording, the length of the recordings, and their resolution. It is similar to that of uploading recordings with ViewXL or Fleet Dashboard, both of which also use Wi-Fi connections. For example, a 15-minute recording at 720p High will use about 2% of battery to upload over a strong Wi-Fi connection.

What is the maximum Wi-Fi upload speed?

Up to 10 Mbps is possible, but dependent on many factors, such as what the network supports.

Will my camera download over Wi-Fi while in Sleep mode?

Yes, it will still check for an approved network every 15 minutes while in Sleep mode.

What happens if the opt-in or opt-out messages are interrupted by a different button press?

The message will disappear and the other action will take precedence. The camera will retry four hours later.

Will the camera upload and download over Wi-Fi at the same time?

Yes.

Icons, LEDs, and sounds

This section lists display icons, LED indications, and haptic feedback signals used by the camera.

Watch this [video](#) for an overview of the feedback your camera provides.

Visual notifications

The display is divided into a Status Bar and Activity Area. Different information displays when the camera is in the field and in an Axon Dock. Some icons may not apply at your organization.

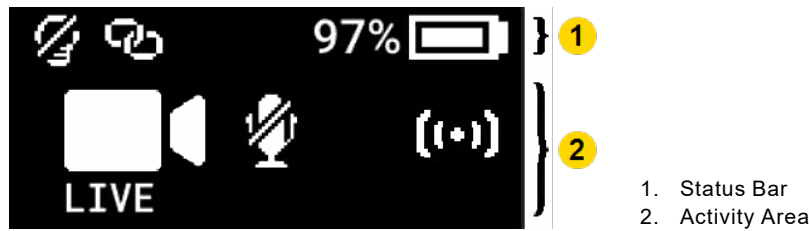

Icons during use

Status Bar Icon	Description
58%	Battery capacity
	Battery charging
	Battery low ($\leq 10\%$)
	Camera paired
	Lights off
S	Stealth mode on

Activity Area Icon	Description	Operation LED
	Axon Respond Livestreaming*	Blinking purple
LOW STORAGE	Memory is 85% full	Blinking red (while recording)
STORAGE FULL	Memory is 95% full	Blinking red (recording stops)



Activity Area Icon	Description	Operation LED
	Mute mode	■■■■ Blinking blue
PAIRING	Pairing mode*	■■■■ Blinking blue
READY	Ready (Buffering) mode	■■■■ Blinking green (also Triad)
	Event (Recording) mode	■■■■ Blinking red (also Triad)
	Recording started by Axon Signal* broadcast	■■■■ Blinking red
	Recording started by gunshot detection	■■■■ Blinking red
	Sleep mode*	Off
n/a	Startup or shutdown	■■■■ Red

* May not be enabled at your organization.

Icons and Triad LEDs while docked

The Triad LED on the front of the camera displays the camera’s dock status.

Display	Description	Triad LED
58%	Battery capacity	
	Battery charging – Triad LED colors show the charge level.	Green: > 90% Yellow: 11-89% Red: <10%
	Battery optimized charging – Charge level is reduced to protect battery health during extended time in dock.	Same as normal charging above
DEVICE ERROR #	Device error #. Refer to the common codes in Troubleshooting on page 39 or the device page in Axon Evidence.	■■■■ Blinking red
NETWORK ERROR	Network error – Check network connection, see device page in Axon Evidence and troubleshooting instructions at help.axon.com .	■■■■ ■■■■ Blinking red and green

Display	Description	Triad LED
	Updating firmware or settings – Camera will resume normal operation after update. Operation LED solid white. Display may also show UPDATING.	 Spinning white
USERID123	User/Badge ID – Displays right after docking, when the camera is charging, for 10 seconds after undocking, and when no other activity is in progress.	n/a
UPLOADING	Uploading – In progress; also shows the number being updated and total, such as 1/5, 2/5, 3/5, and so on.	 Spinning yellow

Audible and haptic notifications

The camera emits audio prompts to notify you of device status. These prompts are accompanied by a vibration (haptic feedback). These prompts usually occur after you perform an action with the camera.

Operating Mode or Action	Audio Notification	Haptic Notification (vibration)
Axon Respond Livestreaming connected	Three short rising-pitch tones	One – long duration
Low battery notifications at 10% and 5% battery capacity	Four quick high-pitch tones	Four – short duration
Marker captured	None	One – short duration
Mute mode, enter or exit	One short tone	Two – long duration
Pairing mode, enter	Three short rising-pitch tones	None
Power off	Three short lowering-pitch tones	One – long duration
Power on	Two short rising-pitch tones	One – long duration
Recording reminder	Two short tones every two minutes	Two – short duration every two minutes
Recording start	Two short tones	Two – short duration
Recording stop, return to Ready mode	One long tone	One – long duration
Sleep mode, enter or exit	One short tone	One – long duration
Stealth mode, exit	None	Two – short duration
Volume up or down	One short tone at new volume level	One – short duration

Admin settings

This section discusses camera settings available in Axon Evidence under **Admin > Devices and Applications > Body Camera > Body Workforce**. Not all settings may be applicable at your organization.

Video

Action	Definition
Quality	Determines the camera's recording quality.

Pre-Event Buffer and Video Recall

Action	Definition
Pre-Event Buffer	Determines the buffer duration included in the final video.
Video Recall	Enables an 18-hour recording buffer.

Watermark

Action	Definition
Watermark	Adds a permanent watermark with date, time, and camera serial number to the upper-right corner of videos.
Watermark Time	Sets the time standard/zone displayed in the recording watermark.

Audio

Action	Definition
Record Audio	Enables audio along with the video.
Pre-Event Buffer Audio	Enables audio in the pre-event buffer.
Audio in Video Recall	Enables audio in Video Recall recordings.

Lights

If enabled, lights can still be configured at the user level on the device.

Action	Definition
Front Light	Illuminates the front-facing Triad camera lights to provide a visible indication of recording status. The lights blink green during pre-event buffering, red when recording.
Automatic Brightness	Enables this mode in the camera and Axon applications. This mode automatically adjusts the brightness of front and top lights based on ambient light. If front lights are disabled, it only applies to top light. Users must have permission to adjust indicator lights to enable Auto mode from the camera or Axon applications, and stealth must be disabled for this setting to be enabled.

Location

Action	Definition
Location in Video	Enables gathering of location data from GNSS/GPS and embedding in video recordings.
Wi-Fi Positioning	Enables gathering of location information from Wi-Fi access points to improve location performance. This also improves battery performance.

Axon Respond

Configure permissions for using Respond features such as Livestreaming in **Roles & Permissions**.

Action	Definition
Livestreaming	Determines when cameras can livestream audio and video to authorized organization users in Respond.
Camera Location on Axon Respond Map	Configures when camera location information is made available to the Axon Respond map.

Evidence upload

Action	Definition
Priority Evidence Upload	Allows users to select recordings for prioritized upload over LTE.
Automatic Wi-Fi Upload	Lets cameras upload video through a connection with nearby organization-trusted Wi-Fi access points. Set trusted Wi-Fi access points on the Body Camera Wi-Fi Networks page.
Wi-Fi Evidence Upload and Firmware Updates	Determines if cameras can upload recordings, download firmware, and sync organization-wide settings through a connection with nearby organization-trusted Wi-Fi Access Points. Organization-trusted Wi-Fi Access Points are set on the Body Camera Wi-Fi Networks page.
Rate-limited Camera Upload Speed	Sets the maximum upload speed in megabits per second for each individual camera.

Axon Signal

Configure assigned personnel activation in Axon Evidence under **Admin > Signal**.

Action	Definition
Signal Activation	Lets camera recording be activated by Axon Signal.

Gunshot detection (beta)

This feature is in a beta stage and may not be available for deployment.

Action	Definition
Gunshot Detection Recording	Determines if the camera starts recording if sensors detect the camera wearer discharging their firearm.
Gunshot Detection Notification	Determines if a notification is sent in near real-time to authorized organization users.
False Gunshot Detection Cancellation	Determines if gunshot alerts can be canceled on the camera. Users can dismiss a false gunshot detection by pressing Select .

Remote activation

Action	Definition
False Remote Activation Cancellation	Determines if Remote Activation alerts can be canceled on the camera. Users can dismiss a Remote Activation alert by pressing Select .

Battery

Action	Definition
Battery Optimized Charging	When enabled, the camera will slowly reduce its state of charge when left in dock for greater than three consecutive days. While this will reduce runtime, it will improve long-term battery health and reduce degradation.

Firmware download

Action	Definition
Firmware Download Timeframe	Adjusts the timeframe in which cameras download a firmware update. A shorter timeframe means cameras download firmware sooner but may result in congestion on your network.

User permissions and mute configuration

Action	Definition
Users Can Mute During Recording	Lets users mute audio when recording an event.
Users Can Use Stealth Mode	Lets users enable Stealth mode on their camera, which disables all lights, audio, and haptic feedback.
Users Can Adjust Indicator Light Settings	Lets users adjust the indicator light settings of their camera.
Users Can Use Sleep Mode	Lets users put their camera in Sleep Mode. Users starting a recording from sleep mode will lose the pre-event buffer. Signal products will not start a recording when a user is in sleep mode. A camera in sleep mode provides a haptic reminder every 15 minutes.

Device management

Action	Definition
Settings return to default in dock	User settings return to default settings when the camera is docked.

Button confirmation

Action	Definition
End Recording Confirmation	Prevents unintentional ending of recordings. With Always , ending a recording requires a secondary confirmation press of Select after every recording. Auto only requires a secondary confirmation after recordings where Event was pressed in the middle of the recording.

Care and maintenance

This section describes cleaning, charging, and storage for the camera.

Never disassemble the camera as this can compromise camera integrity and invalidate the warranty. The camera does not contain a memory card or any user-replaceable parts.

Follow all cleaning agent manufacturer directions.

Clean and disinfect the camera

Cleaning and disinfecting your body camera is simple and easy, but follow these recommendations to avoid causing any damage in the process.

Before cleaning, turn the camera off and disconnect it from any mount, dock, or charging cable.

Surface

- Use a soft, sterile, lightly-moistened (not wet) cloth.
- Use only the approved cleaning agents listed below.
- To reach small areas, use a cotton-tipped applicator.
- Don't immerse the camera in water or cleaning solutions.
- Dry the device fully before use; use a soft lint-free cloth or air-dry.
- Don't spray cleaning agents directly on the camera.
- Don't allow liquid to pool on the camera.

Lens

- Use a lens blower brush to remove debris and wipe with a soft cloth moistened with isopropyl alcohol.
- DO NOT use Windex or similar glass cleaners on the lens; these can contain micro-abrasives that will scratch the lens.
- DO NOT subject the lens to running or pressurized water.

Approved cleaning agents

Many cleaning and disinfecting agents contain ingredients or micro-abrasives that can damage the camera. Use only these approved agents, at the prescribed mix if applicable; do not exceed mix ratios.

- Azowipe
- Bleach (sodium hypochlorite 0.55%) and water solution, 10/90% mix
- Metrex Cavicide, Cavicide 1
- Metrex CaviWipes, CaviWipes 1
- PDI Easy Screen cleaning wipe

- Brulin BruTab 6s tablets
- Clinell universal wipes, universal sanitizing wipes
- Clorox dispatch hospital cleaner disinfectant towels with bleach
- Clorox Formula 409 glass and surface cleaner
- Clorox healthcare bleach germicidal wipes
- Clorox healthcare hydrogen peroxide wipes
- Clorox healthcare multi-surface quat alcohol wipes
- Dish soap, mild
- Diversey D10 concentrate detergent sanitizer
- Diversey Dimension 256 neutral disinfectant cleaner
- Diversey Oxivir Tb wipes
- Diversey Virex II 256 one-step disinfectant cleaner
- Hydrogen peroxide and water solution, 3/97% mix
- Isopropyl alcohol and water solution (including wipes), 70/30% mix
- Isopropyl alcohol and water solution, 91/9% mix
- Medipal alcohol wipes
- PDI Sani-Cloth AF3 germicidal disposable wipe
- PDI Sani-Cloth bleach germicidal disposable wipe
- PDI Sani-Cloth HB sani-germicidal disposable wipe
- PDI Sani-Cloth plus germicidal disposable cloth
- PDI Super Sani-Cloth germicidal wipe
- Progressive Products wipes plus
- Sani professional disinfecting multi-surface wipes
- Sani-Hands instant hand sanitizing wipes
- SC Johnson Windex original glass cleaner with ammonia-d
- Spartan Hepacide Quat II
- Sterets Alcowipe
- Steris coverage plus germicidal surface wipes
- Veridien Viraguard
- WipesPlus hospital/surgical wipes

Charge the battery

Charge the camera battery by placing the camera in the dock or connecting a cable.

Note Ensure the is dry and free of dirt and debris before placing the camera in a dock or connecting a cable.

The dock functions as an ethernet adapter, an unmanaged network switch, and charger. It charges and uploads video to Axon Evidence simultaneously.

When approximately 10% of the battery capacity remains, the camera display shows LOW BATTERY and the camera emits four quick tones and four short vibrations. These alerts repeat at 5% capacity.

Recharge a depleted battery as soon as reasonably possible.

Return cameras to Axon for battery replacement.

Watch this [video](#) for an overview of charging your camera.

Charge without a dock



To charge the camera when no dock is available, use a cable. You should still regularly place your camera in its dock to ensure it has the correct time synchronization and receives the latest firmware updates.

Charge your camera with cable.

1. Connect the camera to the cable.
2. Connect the cable to a power adapter or USB port. A power adapter generally provides more charging power than a device's USB port.
 - If the camera was off, it enters low-power mode and the current charge level appears on the camera display. When you remove the cable, the camera turns off. During charging, power the camera on normally at any time and it enters Ready

mode (buffering).



- If the camera was on, it remains on with the charging icon beside the battery. When you remove the cable, the icon disappears and the camera remains on.

The color of the Operation LED on top provides a visual indication of the charge level. The LED is red  when the charge level is 10% or less, yellow  at 11–89%, and green  at 90% or higher.

Internal clock

Place your camera in an Axon Dock to update the camera's internal clock.

Update firmware

Return your body camera to its networked charging dock on a regular basis, ideally at the end of every daily shift. This will recharge the battery, upload data to Axon Evidence, and download and apply any available firmware updates. While docked, the Status LED on the bottom (now facing up) blinks red  and yellow  while downloading new firmware; avoid removing the camera during a download.

Moisture

Don't charge your camera while the on the camera or dock is wet.

If the is wet, use a paper towel or absorbent cloth to blot the connector and then allow it to fully dry before charging.

If a camera is charging when it gets wet, remove it from the charging source (dock or cable), use a paper towel or absorbent cloth to blot the , and then allow it to fully dry before charging again.

The must be fully dry before placing the camera in a dock or connecting a cable.

Camera storage

-04–95 °F -20–35 °C	Do not store Axon body-worn cameras in environments where the temperature is likely to be outside the maximum (such as under direct sunlight, near heaters, or in a vehicle in extremely hot weather) or minimum values.
70–75 °F 21–24 °C	For long-term storage, ensure room temperature is in this range and battery level is approximately 50% before powering down. Charge the stored camera back to around 50% once a year to prevent over-discharge of the battery. Do not store the camera fully charged or fully discharged.

Troubleshooting

Most issues with your camera can be cleared by restarting it.

If you can't resolve your issue, contact your Axon administrator or Axon technical support at help.axon.com for additional support.

General FAQs

What does the error code on my camera mean?

Error Code 1001 – There is an issue with the digital video recorder. Restart the camera and check if the issue resolves.

Error Code 1004 – There is an issue with the digital video recorder. Restart the camera and check if the issue resolves.

Error Code 1006 – There is an issue connecting with Axon Evidence for video uploads. It can be resolved by un-docking and re-docking the camera.

If you are still unable to resolve the errors, initiate an RMA (return merchandise authorization) to replace your device.

I don't see all the camera display icons in your diagrams, or some I used to see are gone now. What happened?

Some icons are for features that not all agencies have. Also, your administrator may have changed the camera display settings for your organization. Also, remember that different information displays when the camera is in the field and in its dock.

If you believe there is an error with your camera, try restarting it. If this doesn't resolve the issue, contact technical support at help.axon.com.

Why is my camera LED cycling through all the colors (blinking red, yellow and green)?

- Check if the camera display shows NETWORK ERROR. Check your network connection. Un-dock and re-dock your device and check if the error resolves.
- Restart the camera and check and check if the error resolves.
- Ensure the dock is registered.
- Refer to the camera's device profile page in Axon Evidence for additional error information.
- If none of the above work, contact technical support at help.axon.com.

I accidentally undocked my camera while it was updating firmware. What do I do?

No special action is needed, nor is your camera damaged. Avoid removing a camera from the dock while firmware is being applied, indicated by the Triad LEDs spinning white . But if it happens:

- If the camera was undocked when downloading the firmware, it resumes downloading the next time it's docked.
- If the camera was undocked while updating firmware, it continues updating until it is completed. Ensure the camera has enough battery power for the update to complete.

Important Never power the camera off while firmware is being applied.

Why does Windows Media Player (WMP) keep playing the wrong audio track?

This is a known issue with WMP and dual-track media files. One solution is to select the other audio track in WMP, which is different for each version. Another is to use a different media player, like the free and open-source [VLC Media Player](#) (Axon does not specifically approve use of any one media player).

How do I de-register a body camera from my organization?

An Axon Body Workforce camera does not need to be returned to Axon to be de-registered. Contact technical support at help.axon.com.

Why is the buffer video length shorter than expected?

A recorded video may have a shorter buffer period than expected if:

- You started a recording shortly after turning the camera on, so the preconfigured buffer length has not yet elapsed.
- You ended one recording and started another before the preconfigured buffer length elapsed.
- The buffer is off or set to a different duration than expected in Axon Evidence.

Why can't I mute the video audio while recording?

This feature must be enabled in the Admin section of your Axon Evidence account. To use, see [Mute audio recording](#) on page 11.

Why is the time/date on my videos off?

See [Axon Camera Video Watermark Timestamp](#) for a discussion of how to set or disable time zone in a camera recording watermark.

Why don't my camera LEDs illuminate?

Your camera may be in Stealth mode. If an **S** icon appears on the display, press **Volume Up ▲** or **Volume Down ▼** for three seconds. The **S** icon disappears from the display and Stealth mode is canceled.

Why can't I add markers while recording?

This feature must be enabled in the Admin section of your Axon Evidence account. To use, see [Add markers while recording](#) on page 12.

Why can't I put my camera in Stealth mode?

This feature must be enabled in the Admin section of your Axon Evidence account. To use, see [Stealth mode](#) on page 11.

Axon Dock FAQs

How do I ensure my dock is connected to the network?

If your dock is connected to the network, LEDs in the ethernet port blink green or amber. The camera will also be able to upload videos to Axon Evidence immediately upon docking.

My dock is registered, so why is "Device Profile" on Axon Evidence empty?

This is a known issue and a fix is in progress.

Why can't Axon Device Manager detect my dock?

When using this option, look for the NFC tag and hold your mobile device near the NFC icon on the dock. For the 1-bay dock, the icon is on the side of the dock nearest to the ethernet port. For the 8-bay dock, the icon is near bay 1, on the side of the dock near the power connection.

Alternatively, switch to the "Scan Code" tab in ADM and scan the 2D OCR code on the back of the dock.

Why can't I access my dock's Device Profile page on Axon Evidence?

Your dock must be registered to use the Device Profile page on Axon Evidence. See the **Axon Dock** PDF on your camera's [product page](#) or start with this online [Introduction](#) topic at my.Axon.

What comes in the box with my dock?

Each dock comes with an ethernet cable, 8-bay power cable and adapter (SKU 100142), and 1-bay power adapter (SKU 71104). See the **Axon Dock** PDF on your camera's [product page](#) or start with this online [Introduction](#) topic at my.Axon.

Camera registration FAQs

Why is my camera not fully charged when I power it on the first time?

Your camera ships partially charged as required by shipping regulations. Connect your dock (s) to the network and dock your camera to charge it. Always recharge a depleted battery as soon as reasonably possible using an Axon Dock. The Triad LEDs indicate charge level; see [Icons and Triad LEDs while docked](#) on page 29.

Why doesn't my camera display any status messages after being docked the first time?

- Your camera might be low on charge out of the box. Wait 10 minutes for the battery to charge.
- Ensure your dock has power.
- Remove your camera from the dock and re-dock it.

If none of these steps work, [initiate a return](#) with Axon to replace the camera.

How can I identify which camera failed preparation when multiple cameras are docked?

Check the serial number of the camera displayed in the error message by tapping **Errors**. The serial number is located on the back of the camera.

My camera displays NOT ASSIGNED after a successful registration. How do I assign a user to this device?

Assign cameras to users with [Axon Device Manager](#) (ADM) or through Axon Evidence.

To assign through Axon Evidence:

1. Ensure you have the correct permissions to assign users on Axon Evidence.
2. Select **Inventory**, then **Body Worn Cameras**.
3. Search for your device in the Body Camera search bar by the serial number.
4. Select the camera serial number in the list to go to the camera device profile page. In the Assignee section, select **Reassign**.
5. Enter the user's name and select **Reassign**.

ADM error codes

If there is a problem with preparing the camera, Axon Device Manager (ADM) displays an error.

Tap **Errors** to review the error information on ADM and refer to the following instructions to resolve the issue.

If you are unable to register any cameras, this may be due to a connectivity issue. See [Managing Network Allowed Lists with Axon Cloud Services](#) to ensure the appropriate network ports are open.

If some cameras are registering but others are not, this may be a transient error. A suggested general troubleshooting approach is to:

1. Start with only one camera docked at a time.
2. Attempt to register. If a registration error occurs, tap **Dismiss All** to allow ADM to retry registration.
3. If registration fails again, power the camera off and then on again and repeat the registration process.

Refer to these error codes and suggested actions:

Error Code	Description	Troubleshooting Action
-1	Communication to the camera has failed	<p>Power the camera off and back on, then retry registration.</p> <p>If attempting to register many cameras in close proximity, retry registration with individual cameras.</p> <p>If the error occurs again, tap Dismiss All and allow ADM to retry registration.</p>
33, -7249973, 43, or 49	Camera time is inaccurate	<p>Sign out and back into ADM.</p> <p>Power the camera off and back on, then allow the camera to remain docked for two minutes to allow sufficient time to synchronize the camera time.</p> <p>Confirm your organization network settings allow network communication from dock to Axon Evidence through port 80 and port 443. For details, see Managing Network Allowlists with Axon Cloud Services.</p>
45 or 47	Camera unable to reach internet	<p>Power the camera off and back on, then allow the camera to remain docked for one minute prior to retrying. It takes about 30 seconds to establish an internet connection. Tap Dismiss All and allow ADM to retry the registration.</p> <p>If the error persists after retrying to register several times, check the internet connection and troubleshoot the dock internet connection. Common connection issues include organization firewall settings.</p>
46	Camera unable to reach your organization's Axon Evidence account	<p>Sign out and back into ADM. If you can sign in, retry registration. Otherwise, contact technical support at help.axon.com to see if there are any issues with Axon Evidence.</p>
34, 48, or 50	Camera provisioning issue	<p>Power the camera off and back on, then retry registration.</p> <p>If the error persists, contact your Axon Evidence administrator to confirm that Device Management permission is enabled.</p> <p>If Device Management permission is enabled, contact your Axon representative or technical support at help.axon.com for assistance.</p>

View camera information on the display

View camera information such as serial number on the display using these steps:

1. Press **Power** and **Program** at the same time to enter the device menu. The camera display shows four options: Upload, About, Cellular, and Legal.
2. Use **Volume Up ▲** or **Volume Down ▼** to highlight **About**, then press **Select**. The camera display shows options: Assignee, Firmware, Serial, and Storage.
3. Use **Volume Up ▲** or **Volume Down ▼** to highlight the information you want to view, then press **Select**.
4. Press **Select** to return to the prior options.
5. Press **Event** to return to the normal camera display.

Technical information

Technical support

Visit help.axon.com for support options or call 800-978-2737.

Warranty

Axon Enterprise, Inc. warranty provisions are applicable on all Body system products. See www.axon.com/legal for detailed warranty information.

This warranty does not apply, and Axon shall not be liable for any loss, loss of data, damage, or other liability arising out of:

- a. Damage caused by failure to follow instructions regarding the use of the product;
- b. Damage caused by the use of non-Axon products or the use of cartridges, batteries or other parts, components or accessories not manufactured or recommended by Axon;
- c. Damage caused by abuse, misuse, intentional or deliberate damage to the product, or force majeure;
- d. Damage to a product or part that has been repaired or modified by persons not authorized by Axon or without Axon's written permission, or
- e. If any Axon serial number has been removed or tampered with.

Thus, any handling of the camera that alters the condition of the equipment by unauthorized personnel without proper technical training may result in the immediate loss of the manufacturer's standard warranty coverage by impacting the integrity of the equipment and rendering the quality testing performed by specialized technical personnel impossible after handling the equipment.

Warnings

For a full list of the warning associated with this product, see www.axon.com/legal.

Radio waves

The camera system transmission is in the frequency ranges of 2402–2480 MHz, 2412–2462 MHz, 5150–5350 MHz, 5470–5725 MHz, and 5725–5850 MHz. Additionally, depending on the model number and country, it may transmit in the frequencies listed below:

- AX1023: 699–716 Mhz, 704–716 Mhz, 777–787 MHz, 788–798 MHz, 824–849 MHz, 826.4–846.6 MHz, 1710–1755 MHz, 1710–1780 MHz, 1712.4–1752.6 MHz, 1850–1910 MHz, 1852.4–1907.6 MHz



- AX1024: 703–748 MHz, 832–862 MHz, 880–915 MHz, 1710–1785 MHz, 1920–1980 MHz, 2500–2570 MHz
- AX1025: 703–748 MHz, 824–849 MHz, 880–915 MHz, 1710–1785 MHz, 1920–1980 MHz, 2500–2570 MHz

FCC compliance statement

Changes or modifications to the equipment not expressly approved by the manufacturer could void the product warranty and the user's authority to operate the equipment.

Your wireless device (model AX1023) is a radio transmitter and receiver. It is designed and manufactured not to exceed the emission limits for exposure to radio frequency (RF) energy set by the Federal Communications Commission (FCC) of the U.S. Government. These limits are part of comprehensive guidelines and establish permitted levels of RF energy for the general population. The guidelines are based on standards that were developed by independent scientific organizations through periodic and thorough evaluation of scientific studies. The standards include a substantial safety margin designed to assure the safety of all persons, regardless of age and health. Before a device model is available for sale to the public, it must be tested and certified to the FCC that it does not exceed the limit established by the government-adopted requirement for safe exposure.

Axon equipment (models AX1023 and AX1027) has been tested and found to comply with the limits for Class B digital devices, pursuant to part 15 of the FCC Rules. These limits are designed to provide reasonable protection against harmful interference in a residential installation. This equipment generates, uses and can radiate radio frequency energy and, if not installed and used in accordance with the instructions, may cause harmful interference to radio communications. However, there is no guarantee that interference will not occur in a particular installation. If this equipment does cause harmful interference to radio or television reception, which can be determined by turning the equipment off and on, the user is encouraged to try to correct the interference by one or more of the following measures:

- Reorient or relocate the receiving antenna.
- Increase the separation between the equipment and receiver.
- Connect the equipment into an outlet on a circuit different from that to which the receiver is connected.
- Consult Axon technical support for help.

Axon equipment (model AX1026) has been tested and found to comply with the limits for a Class A digital device, pursuant to part 15 of the FCC Rules. These limits are designed to provide reasonable protection against harmful interference when the equipment is operated in a commercial environment. This equipment generates, uses, and can radiate radio frequency energy and, if not installed and used in accordance with the instruction manual, may cause harmful interference to radio communications. Operation of this equipment in a residential area is likely to cause harmful interference in which case the user will be required to correct the interference at his own expense.

Axon systems comply with part 15 of the FCC Rules. Operation is subject to the following two conditions: (1) This device may not cause harmful interference, and (2) this device must accept any interference received, including interference that may cause undesired operation.

ISED Canada compliance statement

This equipment (model AX1023) complies with the IC RSS-102 radiation exposure limits set forth for an uncontrolled environment.

Énoncé d'exposition aux rayonnements: Cet équipement (modèle AX1023) est conforme aux limites d'exposition aux rayonnements ioniques RSS-102 pour un environnement incontrôlé.

The device for operation in the band 5150–5250 MHz is only for indoor use to reduce the potential for harmful interference to co-channel mobile satellite systems.

Les dispositifs fonctionnant dans la bande de 5150 à 5250 MHz sont réservés uniquement pour une utilisation à l'intérieur afin de réduire les risques de brouillage préjudiciable aux systèmes de satellites mobiles utilisant les mêmes canaux.

Section 8.4 of RSS-GEN

Axon systems (models AX1023, AX1026, and AX1027) comply with Industry Canada License-exempt RSS standard(s). Operation is subject to the following two conditions: 1) this device may not cause interference, and 2) this device must accept any interference, including interference that may cause undesired operation of the device.

Systèmes Axon (modèles AX1023, AX1026, et AX1027) est conforme aux normes d'exemption de licence RSS d'Industrie Canada. Son utilisation est soumise aux conditions suivantes : 1) cet appareil ne doit pas causer de brouillage, et 2) doit accepter tout brouillage, y compris le brouillage pouvant entraîner un fonctionnement indésirable.

These digital apparatus (models AX1023 and AX1027) comply with Canadian ICES-003 Class B. Digital apparatus model AX1026 complies with Canadian ICES-003 Class A.

Ces appareils numériques (modèles AX1023 et AX1027) sont conformes à la norme canadienne NMB-003 Classe B. Appareil numérique modèle AX1026 conforme à la norme canadienne NMB-003 Classe A.

THIS AXON SYSTEM MEETS THE GOVERNMENT'S REQUIREMENTS FOR EXPOSURE TO RADIO WAVES.

CE SYSTÈME AXONE RÉPOND AUX EXIGENCES DU GOUVERNEMENT EN MATIÈRE D'EXPOSITION AUX ONDES RADIO.

Declaration of conformity and EU compliance statement

Axon declares that this Axon system is compliant with the requirements of the Radio Equipment Directive (RED) 2014/53/EU and the Electromagnetic Compatibility (EMC) Directive 2014/30/EU of the European Parliament and of the Council. A copy of the original Declaration of Conformity is at www.axon.com/legal.

Country of origin: Finished in the U.S. with U.S. and imported parts.

Compliance marks

Also see axon.com/legal/compliance-documentation.

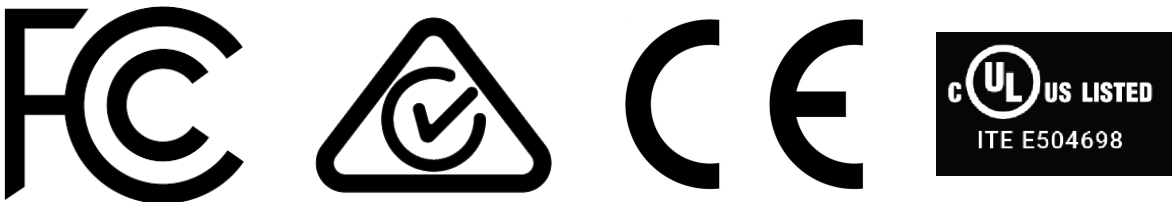

TA 2020-6384
APPROVED



RCPAXAX20-2577

Portuguese:

ANATEL: 16084-20-10342

Incorpora produto homologado pela Anatel sob número 05289-18-01568

H-31844



Este equipamento não tem direito à proteção contra interferência prejudicial e não pode causar interferência em sistemas devidamente autorizados.

Máximo valor de SAR: 1,220 W/kg

URCA_TA_2020_197

Japan



Labeling information

View camera information such as serial number on the display using these steps:

1. Press **Power** and **Program** at the same time to enter the device menu. The camera display shows four options: Upload, About, Cellular, and Legal.
2. Use **Volume Up ▲** or **Volume Down ▼** to highlight **Legal**, then press **Select**.
3. The camera display will automatically scroll the following information. Optionally, use **Volume Up ▲** or **Volume Down ▼** to scroll manually.

For model AX1023

- Model: AX1023
- FCC ID: X4GS01200
- IC: 8803A-S01200
- Contains FCC ID: X4GAB7610
- Contains IC: 8803A-AB7610
- ICES-3(B)/NMB-3(B)

For model AX1025

- Model: AX1025
- ANATEL ID: 16084-20-10342
- Módulo incorporado: ANATEL 05289-18-01568

4. Press **Event** to return to the normal camera display.